

T. SHANKS.
Belt-Tightener.

No. 205,916.

Patented July 9, 1878.

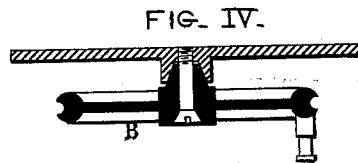
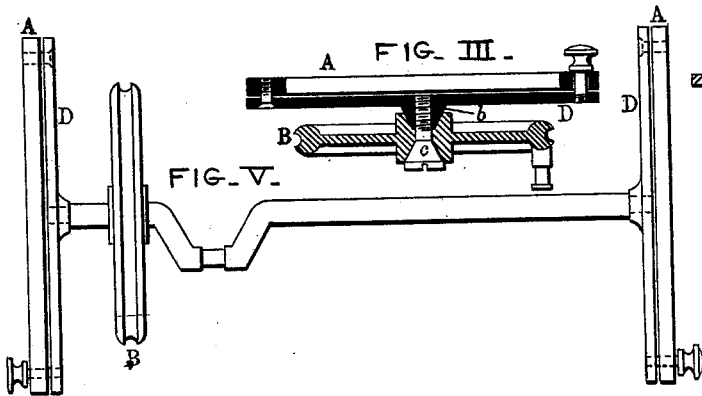
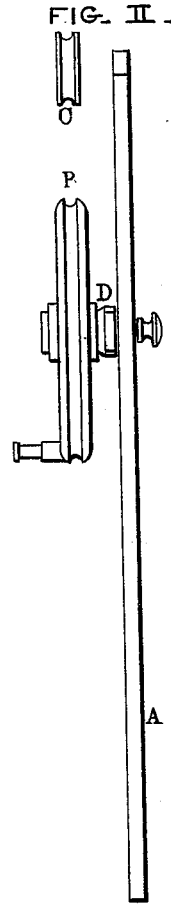
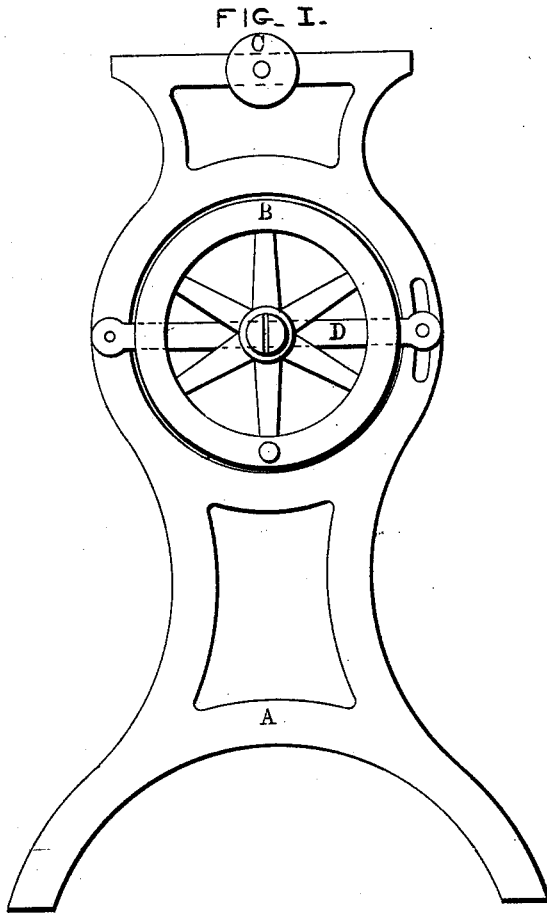

—WITNESSES—

N. P. Cowe
L. Bacon

—INVENTOR—

Thomas Shanks,
by W. M. J. Howard
Attorney.

UNITED STATES PATENT OFFICE.

THOMAS SHANKS, OF BALTIMORE, MARYLAND.

IMPROVEMENT IN BELT-TIGHTENERS.

Specification forming part of Letters Patent No. **205,916**, dated July 9, 1878; application filed February 23, 1878.

To all whom it may concern:

Be it known that I, THOMAS SHANKS, of the city of Baltimore and State of Maryland, have invented an Improved Device for Tightening Belts, of which the following is a specification; and I do hereby declare that in the same is contained a full, clear, and exact description of my said invention, reference being had to the accompanying drawing, and to the letters of reference marked thereon.

This invention relates to a device for the above-named purpose, to be applied to sewing-machines, lathes, &c.; and it consists, first, in suspending the driving-pulley of a machine by means of a vibratory lever, through the medium of which it may be moved toward and from a second pulley, to which the first-named pulley is connected by a belt.

The said invention consists, secondly, in the manner of attaching the movable or driving pulley to the vibratory lever, as will hereinafter fully appear.

In the drawing forming a part hereof, Figures 1 and 2 are exterior views of a leg of a sewing-machine having my improvements attached thereto. Fig. 3 is a partly-sectional view of parts of the invention, and Figs. 4 and 5 illustrate modifications in the construction of certain parts of the same.

Similar letters of reference indicate similar parts of the invention in all the figures.

A represents the leg of a sewing-machine frame, and B the driving-wheel, which is operated by means of a rod from the treadle. C is the pulley, to be driven from the wheel B through the medium of the belt. D is a vibratory lever, pivoted at one end to the leg A, and at the other end provided with a thumb screw or nut, by means of which, in connection with a slot in the leg A, the lever may be held in any position within the range of its vibratory movement.

By means of the arc-shaped slot in the leg A and the thumb-nut, the distance between the centers of the driving and driven pulleys may be regulated with the greatest nicety—a result which cannot be accomplished by other means with which I am familiar.

The wheel B rotates on a conical stud, *b*, projecting from the lever D, and is held in place upon the stud by means of a screw-bolt, *c*, in the end thereof. In supporting the wheel

B, as described, wear of either the stud or wheel is easily taken up by tightening the screw-bolt *c*.

Equivalent devices for taking up the wear of the stud and wheel are shown in Fig. 4, and consist in forming the stud on the wheel instead of on the lever, as shown in the preceding figures.

In Fig. 5 the invention is shown applied to a crank-shaft carrying the driving-wheel, in which case two vibratory levers are used instead of one.

The application of this invention to a sewing-machine or lathe renders the shortening of the driving-belt unnecessary, the belt being tightened by merely increasing the distance between the driving-wheel and pulley through the medium of the lever D.

I do not claim, broadly, tightening a belt by increasing the distance between the axes carrying the pulleys. Neither do I claim, broadly, conical axial bearings for pulleys; but,

Having thus described my invention, what I claim as new, and wish to secure by Letters Patent of the United States, is—

1. The pivoted lever D, having at its free end a securing device and carrying the driving-pulley B, combined with the frame A, provided with a slot in the form of an arc of a circle, by means of which securing device and slot the lever may be held at any point within the range of its vibration, substantially as specified.

2. The slotted frame A and driven pulley C, combined with the vibratory lever D, carrying the driving-pulley B and a securing device, whereby the distance between the centers of the two pulleys may be nicely regulated for the purpose of tightening the belt, as specified.

3. The vibratory lever D and driving-wheel B, each having a conical axial bearing, as described, combined with the screw-bolt *c*, as and for the purposes specified.

In testimony whereof I have hereunto subscribed my name this 8th day of February, in the year of our Lord 1878.

THOMAS SHANKS.

Witnesses:

W. W. WHARTON,
GEO. McCAFFRAY.